

Structural and Thermal Analysis of Brake Drum

Anup Kumar and R. Sabarish

Department of Mechanical Engineering,
Bharath University, Chennai-600 073, India

Abstract: The brake drum is a critical component that experiences high temperatures and develop thermal stresses during application of brakes. In addition, the application of shoe pressure gives rise to mechanical loads. So the analysis takes into account both the thermal stresses and mechanical stresses together. Since the analytical solution is not possible due to combination of loads and varying of contour of the brake drum, it is necessary to carry out finite element approach in order to evaluate the exact stress distribution and make sure that the stress values are well below the allowable limits. Drum modeled here is, of the internal expanding type brake. The shoes of this kind of brake are contained within the drum and expand outwards when the brake is applied. Such kind of brakes is used in medium heavy-duty vehicles.

Key words: Brake drum • Transient thermal analysis • Steady-state analysis • Temperature distribution.

INTRODUCTION

A brake is a device which is used to bring to rest or slow down a moving body. Safe operation of vehicle demands dependable brakes is required to absorb the kinetic energy of the moving parts or the potential energy of the object being lowered by host when the rate of descent is controlled. The energy absorbed by brakes is dissipated in the form of heat. This heat is dissipated in the surrounding atmosphere to stop the vehicle, so the brake system should have following requirements:

- The brakes must be strong enough to stop the vehicle with in a minimum distance in an emergency.
- The driver must have proper control over the vehicle during braking and vehicle must not skid.
- The brakes must have well anti fade characteristics i.e. their effectiveness should not decrease with constant prolonged application.
- The brakes should have well anti wear properties.

Braking Equipment: The braking equipment of a vehicle includes all of its brake system that is all of reducing velocity of a moving vehicle, reducing its rate of acceleration, increasing its rate of deceleration, halting the vehicle and preventing the vehicle from returning movement once it is stationary [1-3].

Experimental Setup Brake Drum Assembly

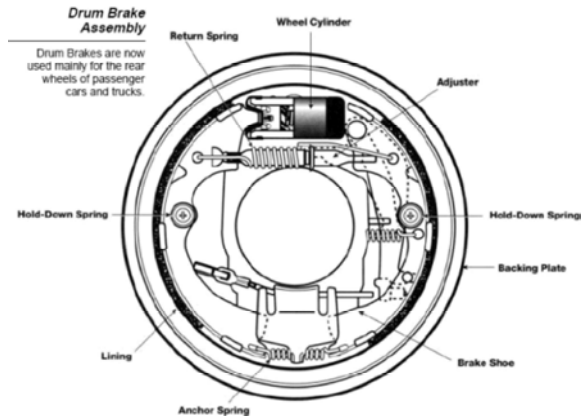

Brake Drum Assembly: The drum brakes have been more widely used than any other brake design. Braking power is obtained when the brake shoe are pushed against the inner surface of the drum which rotates together with axle.

These types of brakes are mainly used for the rear wheels of the passenger cars and trucks while disc brakes are used extensively for the front brakes because of their greater directional stability.

The backing plate is a pressed steel plate, bolted to the rear axle housing. Since the brake shoes are fitted to the backing plate, all of the braking force acts on the backing plate [4-5].

The important requirements of the brake drum are following:

- It should provide a surface having well anti wear qualities.
- It should allow the optimum rate of heat transfer.
- Heat is generated during each brake application and it must be dissipated to the atmosphere immediately, because the next brake application would again produce more heat. Any excess heating of brakes would cause the drum to expand resulting in loss of effective pedal travel and fading of brake lining.
- It should have sufficient strength but minimum weight.
- It should be able to be accommodated within the wheel space available.

Steady-State Thermal Analysis: Steady-state thermal analysis to determine temperatures, thermal gradients, heat flow rates and heat fluxes in an object that are caused by thermal loads that do not vary over time. Such loads include the following:

- Convections
- Radiation
- Heat flow rates
- Heat fluxes (heat flow per unit area)
- Heat generation rates (heat flow per unit volume)
- Constant temperature boundaries

A steady-state thermal analysis may be either linear, with constant material properties; or nonlinear, with material properties that depend on temperature. The thermal properties of most material do vary with temperature, so the analysis usually is nonlinear. Including radiation effects also makes the analysis nonlinear [6-10].

Transient Thermal Analysis: Transient thermal analysis determines temperatures and other thermal quantities that vary over time. Engineers commonly use temperatures that a transient thermal analysis calculates as input to structural analyses for thermal stress evaluations. Many heat transfer applications - heat treatment problems, nozzles, engine blocks, piping systems, pressure vessels, etc. - involve transient thermal analyses. The main difference is that most applied loads in a transient analysis are functions of time. To specify time-dependent loads, you can either use the Function Tool to define an

equation or function describing the curve or then apply the function as a boundary condition, or you can divide the load-versus-time curve into load steps [11-13].

Structural Analysis: Structural analysis is probably the most common application of the finite element method. The term *structural* (or *structure*) implies not only civil engineering structures such as bridges and buildings, but also naval, aeronautical and mechanical structures such as ship hulls, aircraft bodies and machine housings, as well as mechanical components such as pistons, machine parts and tools.

Problem Definition: The original brake drum that has been used previously is modified for some functional requirements. Due to the modification the dimensions and the profile of the brake drum has been changed. As the brake drum is having a modified geometry, it is necessary to check that it functions properly under given load conditions.

Specifications of Brake Drum:

- Mass of the vehicle unladen = 4540 kg
- Mass of the vehicle laden = 8300 kg
- Rolling radius of tyre = 389 mm
- Coefficient of friction (μ) = 0.36
- Shoe contact angle = 95.5°
- Shoe width = 20 mm
- Brake drum internal diameter = 416 mm
- Brake drum external diameter = 470 mm
- Brake drum width = 178 mm

Material Properties of Brake Drum:

- Material=Gray Cast Iron B.S.1452, Grade 250
- Thermal conductivity (k)=0.0544 W/mm°C
- Young's modulus = 1×10^5 N/mm²
- Ultimate strength = 250 N/mm²
- Mass of the drum = 40 kg
- Convection film coefficient=0.001 W/mm²°C
- Thermal expansion coefficient = 9×10^{-6} /°C
- Density = 7.822×10^{-6} Kg /mm³
- Specific heat = 410 Joules

Road Test Data at 60KMPH - Engine is disconnected (Fully Laden)

Speed (KMPH)	Stopping Distance (m)	Deceleration (m/s ²)	Average Deceleration (m/s ²)
59.73	26.76	6.19	6.40
60.46	27.24	6.38	
60.54	25.74	6.64	

Boundary Conditions Applied:

- Convection film coefficient= $0.001 \text{ W/mm}^2\text{°C}$
- Thermal expansion coefficient = $9 \times 10^{-6}/\text{°C}$
- Density= $7.822 \times 10^{-6} \text{ Kg/mm}^3$
- Specific heat= 410 Joules
- Thermal conductivity (k) = $0.0544 \text{ W/mm}^2\text{°C}$

Solid Modeling: The first step was to prepare a solid model of the brake drum. This was carried out using solid modeling package Pro Engineer Wildfire. The detailed drawing was provided



Pro - E model

ELEMENTS

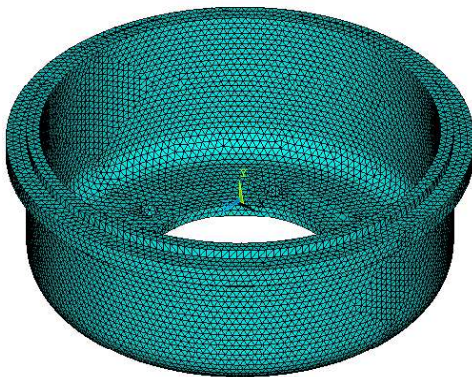

Meshed Model
Meshed Model:

- Solid 70 is used as an element.
- Free mesh had been done.
- Element size is 7.5.
- Total numbers of elements are 92747.
- Total numbers of nodes are 23201.

Analysis result for 30cycles:

MODAL SOLUTION
STEP=30
SUB =4
TIME=62.6
TEMP (AVG)
RBY=0
SDV =30
SDE =34.762

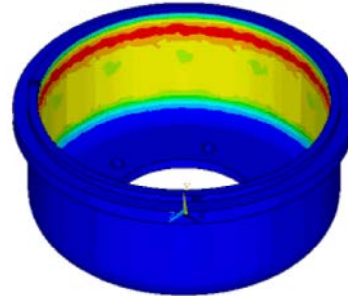

POST26
TEMP 2

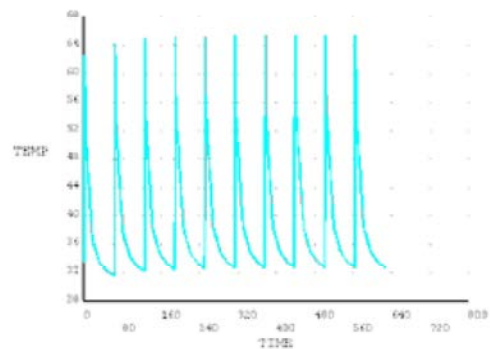

Graphical Result for 30 Cycles
Loads:

- Interior temperature = 100°C
- Exterior temperature = 35°C

MODAL SOLUTION
STEP=1
SUB =1
TIME=1
SEQV (AVG)
SDV =.147648
SDE =3.934
SDE =64.988

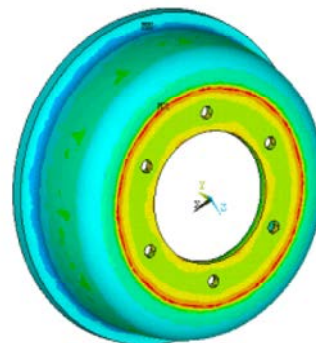

Inner Temperature 100°C

Coupled-Field Analysis: A coupled-field analysis is a combination of analyses from different engineering disciplines (physics fields) that interact to solve a global engineering problem; hence, we often refer to a coupled-field analysis as a multiphysics analysis. When the input of one field analysis depends on the results from another analysis, the analyses are coupled.

Some analyses can have one-way coupling. For example, in a thermal stress problem, the temperature field introduces thermal strains in the structural field, but the structural strains generally do not affect the temperature distribution. Thus, there is no need to iterate between the two field solutions. More complicated cases involve two-way coupling. A piezoelectric analysis, for example, handles the interaction between the structural and electric fields: it solves for the voltage distribution due to applied displacements, or vice versa. In a fluid-structure interaction problem, the fluid pressure causes the structure to deform, which in turn causes the fluid solution to change. This problem requires iterations between the two physics fields for convergence.

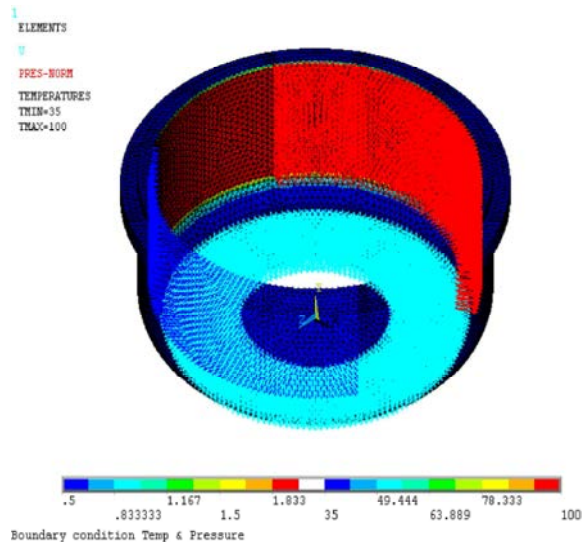

Steady State Boundary Condition with Shoe Pressure:

The coupling between the fields can be accomplished by either direct coupling (matrix coupling) or sequential coupling (load vector coupling). Load transfer can take place across surfaces or volumes. Coupling across fields can be complicated because different fields may be solving for different types of analyses during a simulation. For example, in an induction heating problem, a harmonic electromagnetic analysis calculates Joule heating, which is used in a transient thermal analysis to

predict a time-dependent temperature solution. The induction heating problem is complicated further by the fact that the material properties in both physics simulations depend highly on temperature. Some of the applications in which coupled-field analysis may be required are pressure vessels (thermal-stress analysis), fluid flow constrictions (fluid-structure analysis) and induction heating (magnetic-thermal analysis).

RESULT

Case	Exterior temp in°C	Interior temp in°C	Maximum Thermal stress in N/mm ²	Maximum Deformation in mm	Max Stress due to temp & pressure in N/mm ²
1	35	100	64.988	0.457	132.43
2	100	200	170.554	0.614	206.79

CONCLUSION

From the transient temperature it is observed that the temperature is increasing with each cycle. This shows that the cooling time provided is not sufficient to cool the drum. Also it is seen that the temperature is tending towards a steady state value, which need to be confirmed by further analysis with more number of cycles.

Determination of convection co-efficient (h) value by analytical or experimental prediction and incorporation into model will yield more accurate temperature distributions. The design check has been done by comparing the maximum obtained stress, obtained in analysis against the standard allowable stress value. It was found that the design is safe and the brake drum functions properly under the given load conditions.

REFERENCES

1. Prabhu, T.J., 2005. Design of Transmission Elements' T.J. Prabhu, pp: 13-1.
2. Giri, N.K., 2005. Automobile Mechanics' Khanna Publisher, pp: 381-396.
3. Gupta, R.B., 1997. Automobile engineering' Satya Prakashan.
4. Narang, G.B.S., 2003. Automobile engineering' Khanna Publisher, pp: 287.
5. Gupta, K.M., 2002. Automobile engineering' Umesh Publisher, pp: 112.
6. Heat and Mass Transfer Data Book, 2007.
7. Fabrication, 2007. testing and thermal analysis of metal matrix composite brake drum. 'International Journal of Vehicle Design, 44: 339-359.

8. Numerical and analytical investigation of temperature distribution in a brake drum with simulated defects. 'International Journal of Vehicle Design, 2001. 26: 146-160.
9. Transient Thermoplastic Analysis of Disc Brake Using Ansys.
10. Kurdi *et al.*, [4] one of the most important steps in development of a new truck chassis is the prediction of fatigue life span and durability loading of the chassis frame.
11. Cicek Karao a journal on analysis of a chassis frame with joints was performed by using software.
12. Abd-Rahmin, R., M.N. Tamin and O. Kurdi, A Journal on Stress Analysis of Heavy Duty Truck Chassis using FEM.
13. Sefa Kuralay, N. and Cicek Karao, a Journal on "Stress Analysis of a Truck Chassis with Riveted Joints.