

Analysis of Power Screw Using ‘Ansys’

A. Thirugnanam, Amit Kumar and Lenin Rakesh

Department of Mechanical Engineering,
Bharath Institute of Science and Technology, P.O. Box: 600073 Chennai, India

Abstract: A power screw is designed to translate radial motion into linear motion. Square threads are named after their square geometry. They are the most efficient power screw, but also the most difficult to machine, thus the most expensive. Assumptions made in designing a power screw are: 1) the total load is distributed among the threads. 2) bearing pressure in the thread is uniform. 3) threads are in direct shear. Stresses in screws: 1) tensile or compressive stress in the body of the screw due to an axial load. 2) shear stress due to torque. 3) shear stress in the threads. 4) bearing pressure on the threads. Thus the power screw is designed according to the process and analyzed using ANSYS software. Model developed is to be validated using theoretical calculations. Stresses and torques are studied.

Key words: Square geometry • Thus the most expensive

INTRODUCTION

Screw jacks are simple mechanisms used to drive large loads. A mechanism for lifting and supporting loads, usually of large size. The power screw design of a common Screw jack reduces the amount of force required by the user to drive the mechanism. With the power to magnify input forces, screw jacks allow us to raise vast loads using only a fraction of the force ordinarily needed. Its construction is simple with just few processes involved. Screw Jack is a type of jack which is operated by turning a leadscrew. It is also known as a jackscrew and are commonly used as car-jacks.

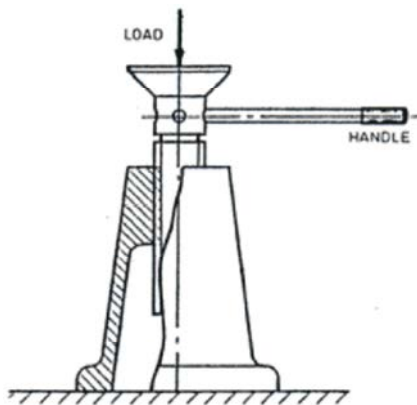

Fig. 1: Screw Jack

The basic principle involved in Screw Jack is the conversion of rotational motion into linear motion. The concept of Screw Jack is the conversion of rotary motion into linear motion. They are provided with a threaded shaft [1]. Threads formed around a shaft are used to translate rotational motion into linear motion. In this way fasteners such as screws and bolts convert the rotational motion or torque of a screwdriver or wrench into a compressional holding force. Screw jack commonly use an Acme thread along the threaded rod. This pattern is very strong and can resist the large loads imposed on most screw jack while not being dramatically weakened by wear over many rotations. Most screw jacks are lubricated with grease. More-sophisticated screw mechanisms may use a re-circulating-ball nut to minimize friction and prolong the life of the screw threads, but such jackscrews are usually not considered self-locking [2].

A screw jack's compressive force is obtained through the tension force applied by its lead screw. An Acme thread is most often used, as this thread is very strong and can resist the large loads imposed on most screw jacks while not being dramatically weakened by wear over many rotations. These types are self-locking, which makes them more intrinsically safe than other jack technologies like hydraulic actuators which require continual pressure to remain in a locked position. Most screw jacks are lubricated with grease [3].

Corresponding Author: A. Thirugnanam, Department of Mechanical Engineering,
Bharath Institute of Science & Technology, P.O. Box: 600073 Chennai, India.

Parameter Used:

Young's modulus of steel (E)= 2.1×10^{-5} N/mm²
 Poisson's ratio of steel (NU)=0.28
 Young's modulus of bronze (E)= 1.2×10^{-5} N/mm²
 Poisson's ratio of bronze (Nu)=0.3
 Pitch=9mm

Design Calculations: "In order to design the screw jack, it is important to determine the various associated parameters such as permissible stresses, yield stresses of the various parts of the screw jack and its required dimensions as per the obtained value of stress and strain [4]."

Permissible Stresses for Screw Material:

Permissible compressive stress $[\sigma_c] = \frac{\sigma_y}{FS} \quad FS=2 = (360/2)$
 = 180

Permissible shear stress calculation $\tau_y =$ yield stress in shear = $(0.5 \text{ to } 0.6) \times \sigma_y$

$$[\tau] = \frac{\tau_y}{FS} = \frac{360}{4} = 90 \text{ N/mm}^2$$

Preliminary Estimate of the Screw Minor Diameter:

Preliminary estimate of the screw minor diameter is obtained, considering the screw to be under pure compression [5].

$$\text{Load on the screw} = W = \frac{\pi d_c^2}{4} [\sigma_e]$$

$$80000 = \pi d_c^2 (180)/4 \quad d_c = 23.78 \text{ mm}$$

Core diameter greater than this value should be chosen, so as to take care of combined loading.

$$p = \text{pitch} = 6 \text{ mm}$$

$$d_c = \text{minor diameter} = 30 \text{ mm}$$

$$d_o = \text{major diameter} = d_c + \text{pitch} = 30 + 6 = 36 \text{ mm,}$$

$$d = \text{mean dia} = \frac{d_o + d_c}{2} = \frac{36 + 30}{2} = 33 \text{ mm}$$

Checking the Screw for Combined Compression and Torsional Load: Torque required to rotate the screw to raise the load,

$$T_1 = W \frac{d}{2} \tan(\phi + \alpha)$$

$$\alpha = \tan^{-1}\left(\frac{p}{\pi d}\right) = \tan^{-1}(6/33\pi) = 3.3^\circ$$

$$T_1 = 80,000 \times 33/2 \tan(3.3 + 8)$$

$$T_1 = 263762.0 \text{ mm}$$

$$\text{Shear stress} = \tau = \frac{16T}{\pi d_c^3} = 49.7 \text{ N/mm}^2$$

Objective of Project: The objective of this thesis is to study the shear stress state of power screw. We calculated the shear stress and torque upon that basis we can analyse by applying the forces. By using Ansys software shear stress was found [6, 7].

CONCLUSION

The theoretical shear stresses of power screw is found manually and then analyzed in ANSYS software. The readings are shown in the tabular column. It is found that comparing with manual results, results are approximate or closer to it. Hence we conclude that ANSYS Software can be used for other analyzing purpose also.

REFERENCES

1. Prabhu, T.J., 2003. Design of transmission elements. Author's Publication.
2. Singh, V.P., 1998. Multi speed gear box design. Khanna Publication.
3. Khurmi, Gupta, R.S., 2000 Machine design. Khanna Publication.
4. Khurmi, R.S., 1997. Theory of machine. Khanna Publication.
5. Rattan, S.S., 1998. Theory of Machines. Dhanpat Rai Publication.
6. Machine design data book, 2003. PSG Publication.
7. Rao, J.S. and R.V. Dukkupati, 1998. Mechanism and Machine Theory.