

## Financial Behavior and Financial Position: A Structural Equation Modelling Approach

*Roza Hazli Zakaria, Noor Ismawati Mohd Jaafar and Sabitha Marican*

Faculty of Economics and Administration, University of Malaya, 50603, Kuala Lumpur, Malaysia

---

**Abstract:** The increasing trend in bankruptcies rate in Malaysia is alarming, particularly among the younger households. The competing explanations for this phenomenon are households are not practicing responsible financial behavior, versus the low and stagnant income in comparison with the increasing cost of living. This study aims to examine the determinants of household financial position, using Structural Equation Modeling (SEM) as the tool of analysis. The data is collected through a self-administrated survey distributed among urban household in Klang Valley, Malaysia. The findings showed that the most dominant determinant of having a good financial position is responsible financial behavior, not income. In turn, responsible financial behavior is strongly related to having sound financial knowledge. For policy purposes, this implies that providing household with financial knowledge and educating them on the need to practice good financial behavior could prove useful in approaching the issue of financially troubled households.

**Key words:** Household Debt • Financial Position • Financial Management • Financial Behavior

---

### INTRODUCTION

Financial environment is getting more challenging, not only for financial institutions and business communities but also for households and individuals. Friendly credit environment, both in terms of credit availability and in terms of more tolerant attitude towards credit could lead to mismanagement of financial resources such as overspending and overborrowing. At the same time, cost of living is increasing not only due to the unavoidable changes in prices of goods and services but also in terms of the increasing needs on goods and services. This is partly due to psychological factors such as having high aspirations level and the urge to keep up with the “better” others in the society. Another development, state withdrawal from providing the usual publicly provided goods such education, healthcare, free highways and security or the decrease in the quality of those state provided goods, too lead to an increase in the cost of living among households. Facing this situation, when the needs and wants keep on increasing but the increase in income is not increasing at the same pace and credit is easily available, households are exposed to the risk of financial mismanagement. This is part of the reason provided to account for the increase in bankruptcies rate, especially for credit card bankruptcies among the younger population.

Malaysia is not spared from this devastating development. The number of individuals declared bankrupt keeps on increasing over the years, from 13 907 in 2008, to 16 228 in 2009 and the figure reached 18 119 in 2010 [1]. Most borrowers who were declared bankrupt aged between 25-44. There is also an increase in the case of “loan sharks” related crime, reflecting an increase in borrowing from the informal financial sector. This dismal statistics has spurred a lot of interest in this issue, both to understand the root of the problems, identifying possible measures and implementing the appropriate policies. In the same vein, this issue has motivated us to undertake this research to understand the determinants of household financial position in Malaysia. Our particular interest is to examine the competing possible explanations, that is it lack of resources (income) or irresponsible financial behavior that lead households to face financial trouble.

**Financial Behavior: Does it Matter for Household Financial Position?:** Household financial behavior refers to how household manage their financial resources, such as planning, budgeting and savings, while financial position is defined as household financial position, that is associated with the ability to provide for household needs and meeting financial obligations. Among issue of interest is whether responsible financial behavior

contributes to a strong financial position, other than having adequate income. Common findings are sound financial behavior is positively related to financial position and even financial satisfaction. Those who adhere to responsible financial behavior report a lower level of financial difficulties [2-4] and higher financial satisfaction [2-5]. This signifies the importance of financial position in ensuring household financial position. Study even finds that financial behavior has the most dominant impact on financial satisfaction, greater than that of income [2]. While another empirical finding find no significant relationship between sufficiency of income and social responsible consumption behaviours [6]. This suggests that there is a possibility that it is household behaviour and not income that explains the rapid increase in the number of bankruptcies rate.

**Determinants of Financial Behavior:** The fundamental role of responsible financial behavior on financial position indicates the importance of understanding what explains responsible financial behavior. A factor that is most prominent is having sound financial knowledge, with the hypothesis that knowledge would positively influence behavior. The finding regarding the relationship of these two variables is conclusive, with all studies find that having financial knowledge does influence individuals to behave in a more financially responsible ways [7-10].

Theoretically, making sound financial decision requires considering a myriad of details such as interest rates, costs, prices, discount rates and time horizons. Many sources of financial information are complex and inaccessible to the average consumer. Consumers have to search for the relevant information and for that, they need to know the relevant details. In other words, they need to be knowledgeable in order to make sound financial decision. This refers to Dunning-Kruger effect where people who do not know much tend not to recognize their ignorance, hence fail to seek better information. Where empirical support is concerned, thus far, studies are in agreement on the significance of having financial knowledge and responsible financial behavior [7, 9-12]. For instance, a study shows that savings, an indicator of responsible financial behavior is also determined by financial literacy [13]. While others [14, 15] report that having financial knowledge reduces the chance of engaging in risky credit and paying behavior such as holding more than four credit cards and bounces a check.

Another factor that recurs in past studies that determine financial behavior is locus of control, referring to individual beliefs on the capacity of their own actions

to determine the final outcomes. It reflects whether individuals are positive that if they manage their finances well, they would be able to achieve the intended outcome which is financial position. There are two extremes of locus of control, internal versus external [10]. Individual with internal locus of control strongly believes that it is their own financial practices that will determine their financial position. Hence, they tend to exhibit more responsible financial behavior. On the other hand, those with external locus of control possess strong conviction that their destiny is largely determined by factors beyond their control such as luck, fate and chance. They are not motivated to demonstrate responsible financial behavior such as controlling spending, careful budgeting and financial planning since in their perceptions, life events are determined by random and external forces.

However, findings on the impact of locus control on financial behavior are mixed. For instance where household debt is concerned, some studies report that those with higher locus of control tend to have higher debt [16-18] finds that locus of control is not a significant determinant of debt decision; while another study finds that those with internal locus of control tend to have more debt, possibly because they are more confident of their ability to manage debt, [19]. Studies that include locus of control as a factor that explain financial behavior or financial position consistently find a negative relationship between external locus of control and responsible financial behavior [7, 10, 21]. In addition, they provide supportive evidence that locus of control mediates the effect of financial knowledge in the sense that given similar level of financial knowledge, those with external locus of control tend to demonstrate lesser control over their finances.

Another important variable in relation to financial behavior is income. Previous studies [9, 22] provide empirical support for the hypothesis that having higher resources results in better financial behavior. For instance, some studies show that recurrent savings is positively related to income [16, 22], while another study finds household savings increase with family income [19]. Another study claims that debt delinquencies are also determined by income [16].

Apart from that, a number of previous studies also include ethnicity following the claim that it is a common perception in the field of financial services that different races behave differently in managing their finances [9]. Empirically, this is supported by the study on the differences between Korean and the Americans financial behavior [10]. Research on financial behavior in Malaysia

also suggests that there exist differences in financial behavior among various ethnics, where for being a Chinese significantly explains individuals' financial behavior [23].

**MATERIALS AND METHODS**

Based on past studies, a model is constructed to examine what determine household financial position. The variables of interest are income and financial behavior since the objective of the paper is to examine these two competing explanations. In addition, given the crucial role of financial behavior as suggested by previous studies, we would also be examining the factors that explain responsible financial behavior. In other words, we are looking at financial behavior as the mediator. Similarly, we believe that knowledge, other than its direct effect on financial behavior, is capable of inducing positive impact on financial behavior, given similar income, ethnicity and locus of control. Hence, financial knowledge is also positioned as a mediator between those factors and financial behavior. The hypothesized model is summarized in Figure 1.

Structural Equation Modeling (SEM) was used to test the hypotheses. The modeling is a combination of exploratory factor analysis and multiple regressions [24]. SEM was chosen due to its capability to link latent variable with its observed variables and with other latent variables. The hypothesized model consists of three latent variables and 22 observed variables (Table 1). Confirmatory Factor Analyses (CFA) was conducted for each unobserved variable to verify the suitability of the identified variables to represent correspond latent variable. Both CFA and SEM are conducted with IBM SPSS Amos 19 using Maximum Likelihood as estimation procedure. Since the data set contain missing data (<1% for each variables), the saturated model and independent model was fitted for computing fit measures.

**Data Sources and Measure of Construct:** Data analysis is done using primary data collected through a self-administrated survey conducted between January and April 2011. Stratified multi-stage sampling method was used thus ensuring that socio-economic and geographical considerations are taken into account to reflect the population of urban working class. A sample of 1000

Table 1: List of Latent Variables in the Model

Financial Behavior Constructs	
A1	Setting money aside for savings
A2	Setting money aside for retirement
A4	Planned to reach my financial goals
A5	Followed a weekly or monthly budget
A11	Paid credit card bills in full and avoided finance charges
Financial Position Construct	
C20	I do not have enough money for doctor, dentist, or medicine
C21	I cannot afford to buy new shoes or clothes
C22	I cannot afford to pay for utilities (e.g. electricity, gas bills)
C31	I cannot afford to keep the car running
C17	I do not have enough money to pay all my bills
C23	I spent more than the money that I had
C24	I had to cut living expenses
C25	I had financial troubles because I did not have enough money
Locus of Control Construct	
D17	When I make plans, I am almost certain that I can make them work
D18	What happens to me is my own doing
D19	Doing things the right way depends upon ability, luck has nothing to do with it
D20	Many of the unhappy things in people's lives are their own responsibility

Table 2: Selected Amos Output for the Hypothesized Cfa Model (Final Model)

Latent Variable	Observed Variables	$\chi^2$	df	RMSEA	Baseline Comparisons Indices				
					NFI	RFI	IFI	TLI	CFI
Financial Behavior	A1, A2, A4, A5, A11	21.868	5	.055	.982	.947	.986	.959	.986
Locus Control	D17,D18,D19,D20	6.886	2	.047	.993	.964	.995	.974	.995
Financial Position	C20,C21,C22,C31 C217,C23,C24,C25	180.730	18	.090	.947	.894	.952	.904	.952

Note:  $\chi^2$ =Chi-square, df=degree of freedom, RMSEA= Root mean square error of approximation, NFI= Normed fit index, RFI= Relative fit index, IFI=Incremental fit index, TLI= Tucker-Lewis coefficient, CFI= Comparative fit index

Table 3: Direct, Indirect and Total Effects Between Variables

Dependent Variable	Independent Variables	Direct Effects	Indirect Effects	Total Effects
Financial Behavior	Ethnicity	-.009	.021	.012
	Income	.232	.087	.319
	Locus of Control	.001	-.019	-.017
	Financial Knowledge	.485	-	.485
Financial Position	Ethnicity	.017	-.003	.014
	Income	-.161	-.077	-.238
	Locus of Control	.233	.004	.237
	Financial Knowledge	.008	-.119	-.111
	Financial Behavior	-.245	-	-.245

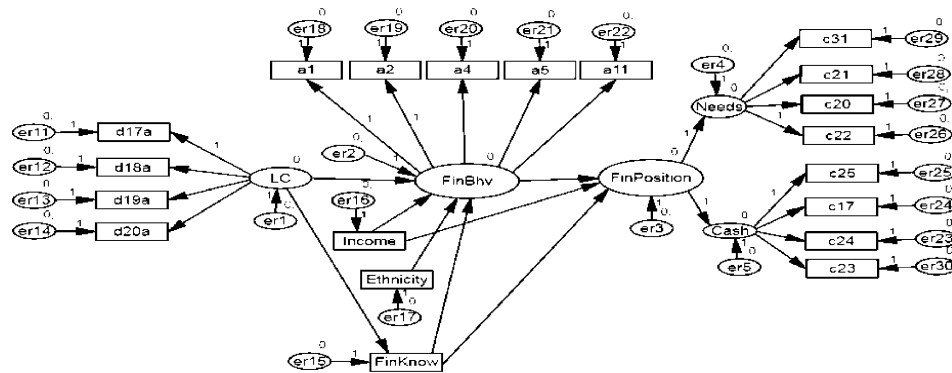

Note: Er=error

Fig. 1: Hypothesized Structural Equation Modeling for Financial Behavior and Financial Position (Initial Model)

CFA for Financial Position

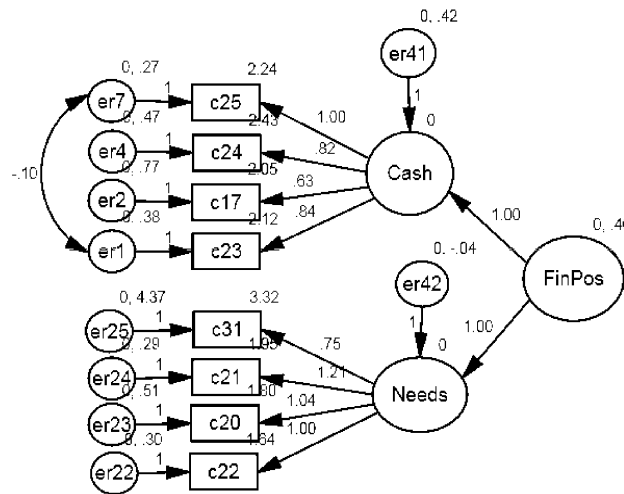

CFA for Locus Control

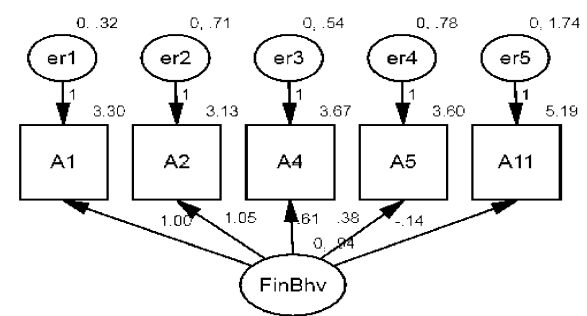

CFA for Financial Behavior

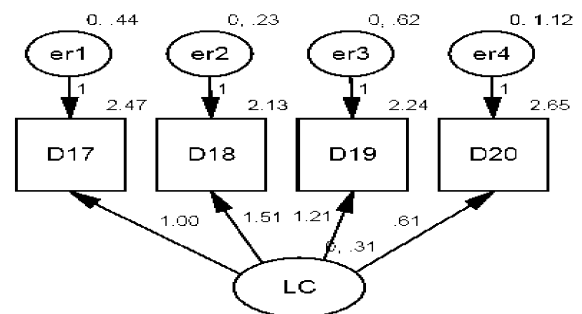

Note: Finpos=financial Position, Finbhv= Financial Behavior, Lc= Locus Control, Er=error.

Fig. 2: Output Path Diagram for Hypothesized Cfa Model.

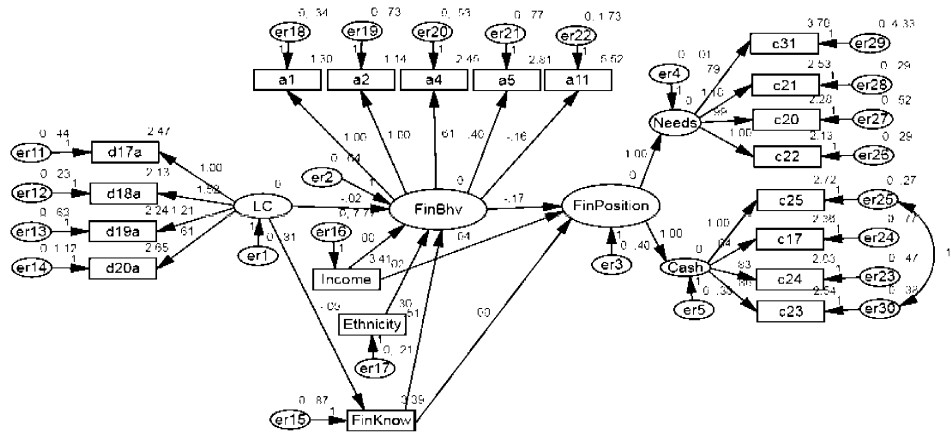

Note:  $\chi^2=984.964$ ,  $Df=160$ ,  $Rmsea=.068$ ,  $Nfi=.858$ ,  $Rfi=.813$ ,  $Ifi=.878$ ,  $Tli=.839$ ,  $Cfi=.877$  Er=error  
 Fig. 3: Hypothesized Structural Equation Modeling for Financial Management and Financial Position (Final Model)

randomly selected head of household lives in Klang Valley, Malaysia were approached in public places by a group of research assistants to fill up a questionnaire form. After screening and data cleaning, only 916 questionnaires were usable.

Financial knowledge was examined by asking, “How would you rate your financial knowledge?” on 5-Likert scale, from excellent to poor, following Joo and Grable [2]. Except for income and ethnicity, the rest of the observed variables were measured by how frequent the respondent had taken the actions using 5-likert scale ranging from 1 as never to 5 as always. Hence, a higher score indicate a more responsible financial behavior. As shown in Figure 1, several observed variables are attached to each of the latent variables.

The measure of construct for Locus Control follows Cosma and Pattarin [18] where a higher scale indicates the more external an individual (head of household) is. We combined the items from index on Frequency of Financial Problems and selective items from [2] that reflect financial difficulties, instead of financial behavior; in measuring household financial position. It measures household ability in meeting their needs and their liquidity (cash) balances. The higher score indicates a more troubled financial position. The items are listed in Table 1.

**Findings**

**Socio-economic Profiles of Respondents:** The distribution of respondent by gender is almost equal with 49% male and 51% female. Majority of them are Malay (57%) followed by Chinese (28%) and Indian (14%). The mean age was 33 years old with a standard deviation of 11.7 years. Three-quarters of respondents were in their 40s or younger. Only small proportion of them never had formal

education (2.4%). Most of them are payroll worker (68%). 77% of the sample reported having household income less than RM5000.00 per month. Majority of them (75%) had medium household size with six household members including four members aged less than 18.

**Confirmatory Factor Analysis:** Test statistics for skewness and kurtosis for all observed variable is between 2 and -2, hence the normality condition of the data is fulfilled. No modification of model is done except for the financial position. In the CFA model for financial position, three variables were correlated to improve the model. The final CFA models for the three investigated latent variables are shown in Figure 2. From Table 2, even though the goodness-of-fit statistics is significant for all three hypothesized CFA models, the value of RMSEA (less than 0.1) and baseline comparison indices (more than 0.9) suggest that the model is fit [26]. This concludes that the proposed observed variables identified for measuring financial position, financial behavior and locus control are significant, hence the hypothesized CFA models are found to be fit with the data.

**Factors Related to Financial Position:** Findings from the path analysis are presented in Figure 3.

**Direct Effects**

**Financial Position:** The findings suggested that self-perception or individual’s locus of control, income and financial behavior determined household financial position. Specifically, those with internal locus of control tend to have better financial position. This suggests that those who believed that they could control their financial situation will display more responsible financial

management. This is consistent with other findings such as [21, 9, 10]. Higher household income and those with more responsible financial behavior also led to better financial position. Yet, it is noted that there are also empirical findings with contradictory results, for instance [28]. No direct effects were found from financial knowledge and ethnicity on financial position.

**Financial Behavior:** As our initial hypothesis, it was determined that financial behaviors were related to income and financial knowledge. Both were positively related, indicating that having financial knowledge led to practicing responsible financial behavior while household with higher income is related to more responsible financial behavior.

**Indirect Effects:** The analysis showed indirect effects from financial knowledge and income to financial position, that is that having financial knowledge led to a better financial position, mediated by responsible financial behavior. Similarly, higher income households tended to demonstrate better financial behavior and the effect is greater if they have financial knowledge.

**Total Effects:** Total effects allow us to identify the merits of each determinant on financial position as well as on financial behavior. Table 3 presents the summary of direct, indirect and total effects. Household financial behavior has the largest impact on household financial position, yet the magnitude of the impact is only marginally higher than that of income and locus of control. On a further note, the impact from financial behavior is a direct effect, implying that practicing financial behavior per se is capable of producing that much positive effect on financial position. However, in the case of income and locus of control, the direct effect is much lower than that.

As for financial behavior, the most influential determinant is financial knowledge, followed by income. Similar to the case of financial position, the impact of financial knowledge on financial behavior is totally based on direct effects while the total effect of income on financial behavior came from its direct effect as well as with financial knowledge as the mediator.

Generally, the findings from this analysis are in agreement with our initial hypothesis. They are also consistent with findings from other studies on household financial behavior for instance those with internal locus of control possessed better financial position, higher income led to better financial behavior and responsible financial behavior is associated with better financial position

[2, 9, 11]. This suggests that what determines urban working class financial position, at least in the case of Klang Valley, Malaysia, is similar to other studies.

This finding suggests household financial position could be improved by practicing responsible financial behavior such as setting aside money for saving and retirement, budgeting and minimizing financial surcharges. Although the model suggested that income and locus of control have impact of similar magnitude on financial position, yet the impact involves other mediators which are financial knowledge and financial behavior. Hence, effort to increase household income per se would not bring a huge improvement on household financial position. Instead, educating household to practice responsible financial behavior might prove to be useful in improving household financial position.

This is further supported by findings on determinants of financial behavior. Having sound financial knowledge is associated with demonstrating good financial behavior and the findings also dictated that financial knowledge had the most dominant impact on financial behavior, suggesting that equipping household with financial knowledge could led them to practice commendable financial behavior, which in turn could lead to a an improvement in their financial position.

## CONCLUSIONS

Motivated by the increasing number of bankruptcy cases in Malaysia, this study is undertaken to understand the determinants of household financial position. Our findings validated the relationship between financial position and financial behavior that has been established by previous studies. Household financial position is predominantly determined by the practice of good financial behavior as well as income and locus of control which represents household perception on their ability to control their financial destiny. In fact, financial behavior mediates the role of income in explaining financial position. As for financial behavior, responsible financial behavior is associated with having better financial knowledge and higher income. Taken together, these implied that introducing financial education to household and promoting good financial practices could possibly help in reducing the compounding problems of increasing number of bankruptcies and household with precarious financial position. Although the findings also claimed the importance of income in determining household financial position, yet, where intervention policy is concerned, eradicating poverty or effort to increase income at large is

more difficult to be implemented as opposed to channeling effort towards creating awareness and educating the general public regarding the need to practice good financial behavior. For future research, it is suggested that gender be examined since some studies highlight its importance effect on financial behavior, [29, 30]. In addition to that, modification on the measure of constructs for financial behavior could be done following [31] for investigating the relationship between financial behavior and financial position.

### REFERENCES

1. Bank Negara Malaysia, 2011. Monthly Statistical Buletin. Bank Negara Malaysia.
2. Joo, S. and J.E. Grable, 2004. An exploratory framework of the determinants of financial satisfaction. *J. Family and Economic*, 25: 25-50.
3. Lea, S.E.G., P. Webley and C.M. Walker, 1995. Psychological factors in consumer debt: Money management, economic socialization and credit use. *J. Economic Psychol.*, 16: 681-701.
4. Dowling, N.A., T. Corney and L. Hoiles, 2009. Financial Management Practices and Money Attitudes as Determinants of Financial Problems and Dissatisfaction in Young Male Australian Workers. *J. Financial Counseling and Planning*, 20: 5-13.
5. Parrotta, J.L. and P.J. Johnson, 1998. The impact of financial attitudes and knowledge on financial management and satisfaction of recently married individuals. *Financial Counseling and Planning*, 9: 59-75.
6. Yasemin Özkan, 2009. The Effect of Some Demographic Characteristics of Turkish Consumers on Their Socially Responsible Consumption Behaviours. *World Applied Sciences J.*, 6(7): 946-960.
7. Hogarth, J.M., M.A. Hilgert and J. Schuchardt, 2002. Money managers: The good, the bad and the lost. *Proceedings of the Association of Financial Counseling and Planning Education*, pp: 12-23.
8. Hilgert, M.A., J.M. Hogarth and S.G. Beverly, 2003. Household financial management: The connection between knowledge and behavior. *Federal Reserve Bull.*, 89: 309-322.
9. Perry, V.G. and M.D. Morris, 2005. Who Is in Control? The Role of Self-Perception, Knowledge and Income in Explaining Consumer Financial Behavior. *J. Consumer Affairs*, 39(2): 299-313.
10. Grable, J.E., J.Y. Park and S.H. Joo, 2009. Explaining financial management behavior for Koreans living in the United States. *The J. Consumer Affairs*, 43: 80-107.
11. Hilgert, M.A., J.M. Hogarth and S.G. Beverly, 2003. Household Financial Management: The Connection between Knowledge and Behavior. *Federal Reserve Bulletin*,
12. Chen, H. and R.P. Volpe, 1998. An analysis of personal financial literacy among college students. *Financial Services Review*. 7(2): 107-128.
13. Lusardi, A., 2008. Household Saving Behavior: The Role of Financial Literacy, Information and Financial Education Programs. NBER Working, pp: 13824.
14. Hayhoe, C.R., L. Leach, M.W. Allen and R. Edwards, 2005. Credit Cards Held by College Students. *Financial Counseling and Planning*, 16(1): 1-10.
15. Xiao, J.J., B. Sorhaindo and E.T. Garman, 2006. Financial behaviours of consumers in credit counseling. *International J. Consumer Studies*, 30(2): 108-121.
16. Lunt, P.K. and S.M. Livingstone, 1991. Psychological, social and economic determinants of savings: Comparing recurrent and total savings. *J. Economic Psychol.*, 12: 621-641.
17. Tokunaga, H., 1993. The use and abuse of consumer credit: Application of psychological theory and research. *J. Economic Psychol.*, 14: 285-316.
18. Cosma, S. and F. Pattarin, 2010. Attitudes, Personality Factors and Household Debt Decisions: A Study of Consumer Credit. Available at SSRN: <http://ssrn.com/abstract=1685765>
19. Wang, L., W. Lu and N.K. Malhotra, 2011. Demographics, attitude, personality and credit card features correlate with credit card debt: A view from China. *J. Economic Psychol.*, 32(1): 179-193 .
20. Nyhus, E.K. and P. Webley, 2001. The role of personality in household saving and borrowing behaviour. *European Journal of Personality*, Special issue: Personality and Economic Behavior, 15: S85-S103.
21. Hira T.K. and O.M. Mugenda, 1999. The relationships between self-worth and financial beliefs, behavior and satisfaction. *J. Family and Consumer Sciences Education*, 91(4): 76-82.
22. Lea, S.E.G., R.M. Tarcy and P. Webley, 1987. *The Individual in the Economy*. Cambridge: Cambridge University Press.

23. Parsa, B., 2008. Financial Status Among the Malaysian Elderly. Unpublished MA Disstertation, University of Putra Malaysia.
24. Ullman, J.B., 2001. Structural Equation Modeling. In B.G. Tabachnick and L.S. Fidell, (Eds.), Using multivariate statistics (4th ed.). Needham Heights, MA: Allyn and Bacon.
25. Fitzsimmons, V.S., T.K. Hira, J.W. Bauer and J.L. Hafstrom, 1993. Financial management: Development of scales. *J. Family and Economic*, 14: 257-273.
26. Schreiber, J.B., A. Nora, F.K. Stage, E.A. Barlow and J. King, 2006. Reporting Structural Equation Modeling and Confirmatory Factor Analysis Results: A Review, *The J. Educational Res.*, 9(6): 323-337.
27. Joo, S., 1998. Personal financial wellness and worker job productivity. Unpublished doctoral dissertation, Virginia Polytechnic Institute and State University, Blacksburg.
28. Narges Delafrooz, Laily Hj Paim, Mohd Fazli Sabri and Jariah Masud, 2010. Effects of Financial Wellness on the Relationship Between Financial Problem and Workplace Productivity. *World Applied Sciences J.*, 10(8): 997-1002.
29. Sarfraz Khan and Mirza Rizwan Sajid, 2011. Effects of Women's Education and Marriage Period on Their Decision Making Power at Household Level in Gujrat-Pakistan. *Middle-East J. Scientific Res.*, 8(2): 407-415.
30. Maryam Esfahani Asl and Mohammadreza Bayat, 2011. Relationship between Emotional Intelligence and Achievement Motive with Locus of Control among Female Nurses in North Part of Khuzestan in 2009. *Middle-East J. Scientific Res.*, 9(2): 184-188.
31. Tooraj Sadeghi and Sahel Farokhian, 2011. The Role of Behavioral Adoption Theories in Online Banking Services. *Middle-East J. Scientific Res.*, 7(3): 374-380.